

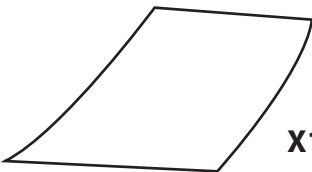

# CONSTRUCTION DE LA MAQUETTE DE L'ANCIEN PALAIS DE BRUXELLES

## LE PALAIS DU COUDENBERG

### Matériel

 X19	 X1	 X1	 X1
19 feuilles A4 dont 2 épaisses pour le plan	1 paire de ciseaux	colle et/ou papier collant	

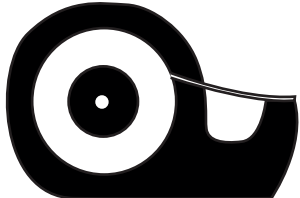
### Instructions de montage

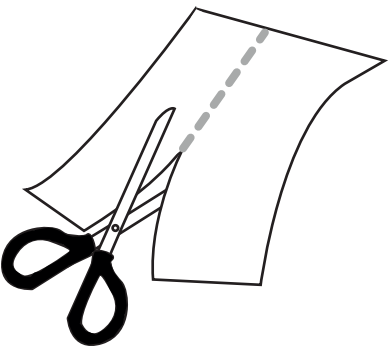
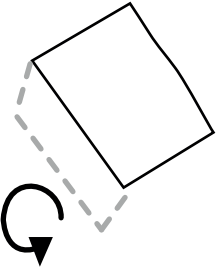
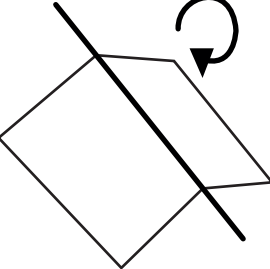
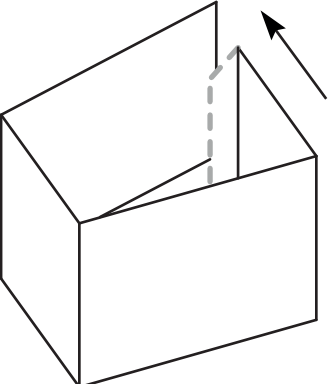
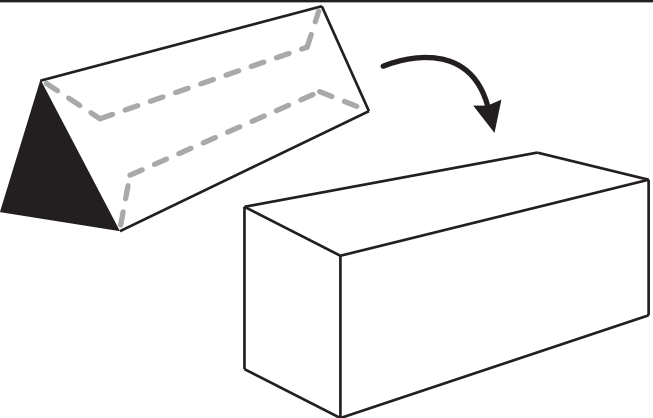
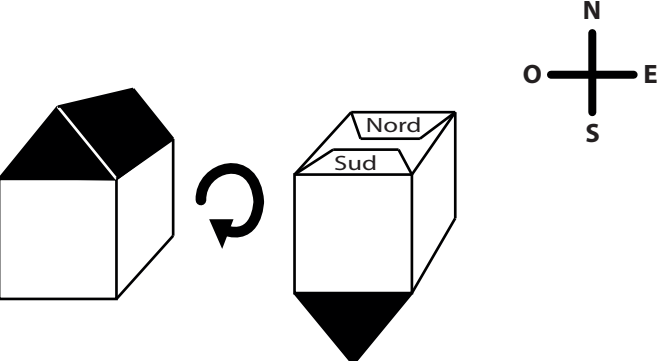
			
1. Découper le long des pointillés.	2. Plier les rabats.	3. Plier le long des lignes.	4. Coller les rabats pour fermer les bâtiments.
			
5. Coller les toits sur les bâtiments.	6. Situer les bâtiments sur le plan grâce aux indications et les coller.		

0. PLAN DE MASSE

PARC ET

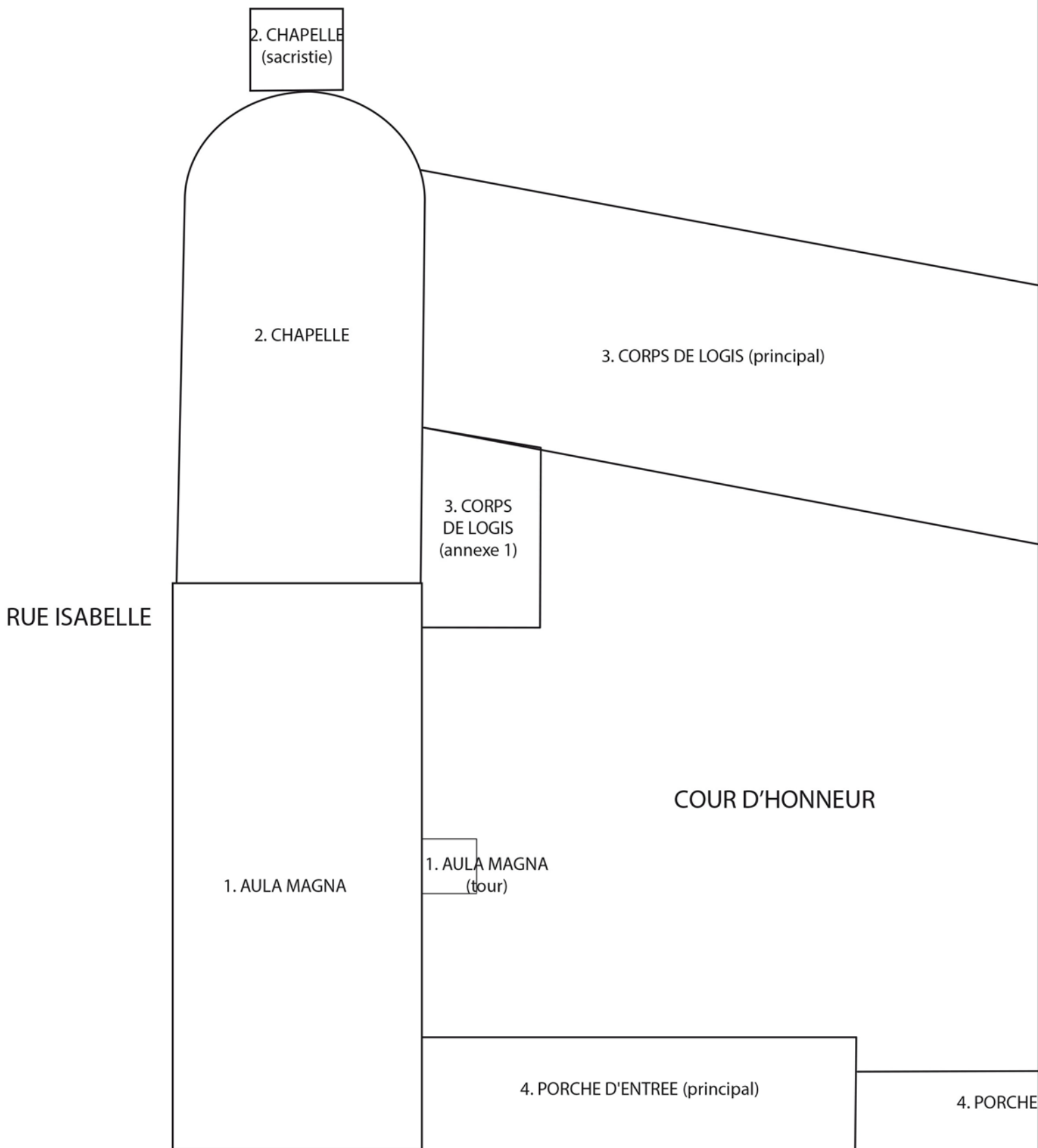

RUE ISABELLE

2. CHAPELLE  
(sacristie)

2. CHAPELLE

3. CORPS DE LOGIS (principal)

3. CORPS  
DE LOGIS  
(annexe 1)

1. AULA MAGNA

1. AULA MAGNA  
(tour)

COUR D'HONNEUR

4. PORCHE D'ENTREE (principal)

4. PORCHE

PLACE

JARDINS

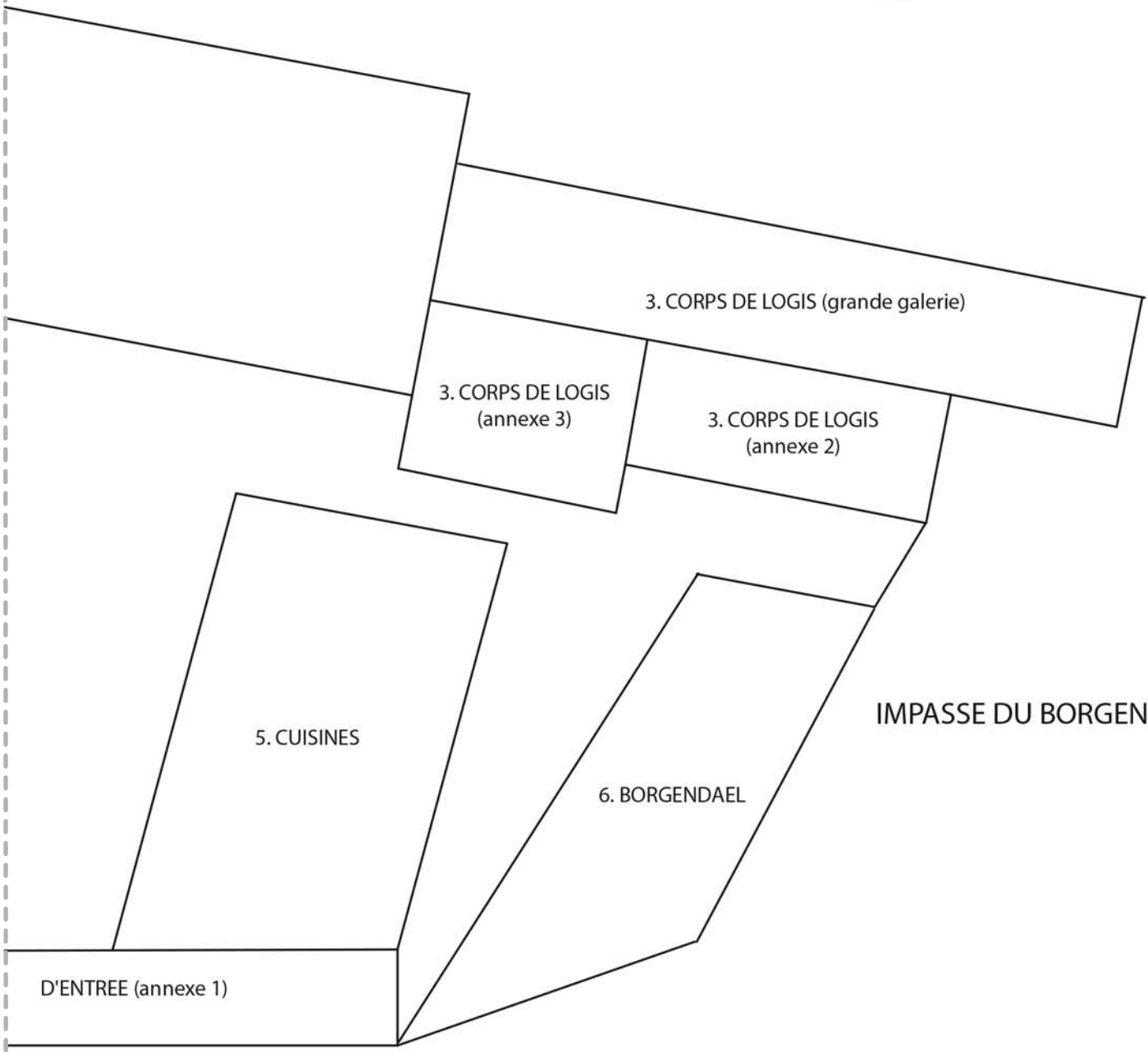
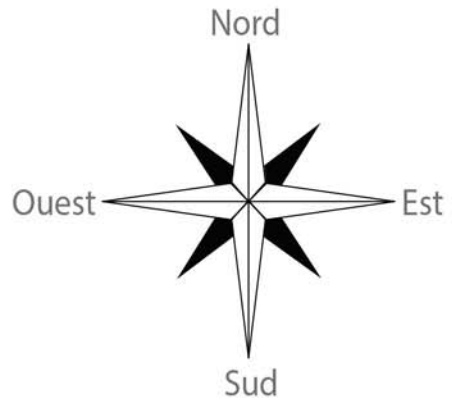

IMPASSE DU BORGENDAEL

DES BAILLES

## Consigne de montage de l'Aula Magna

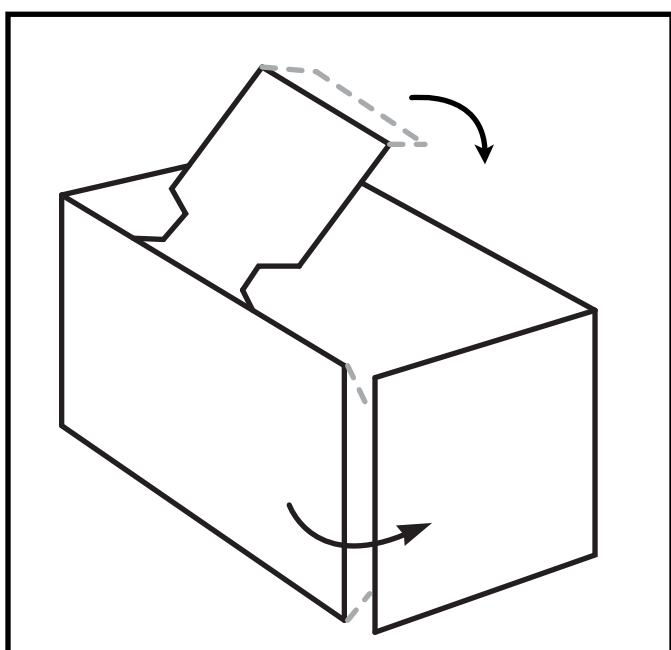
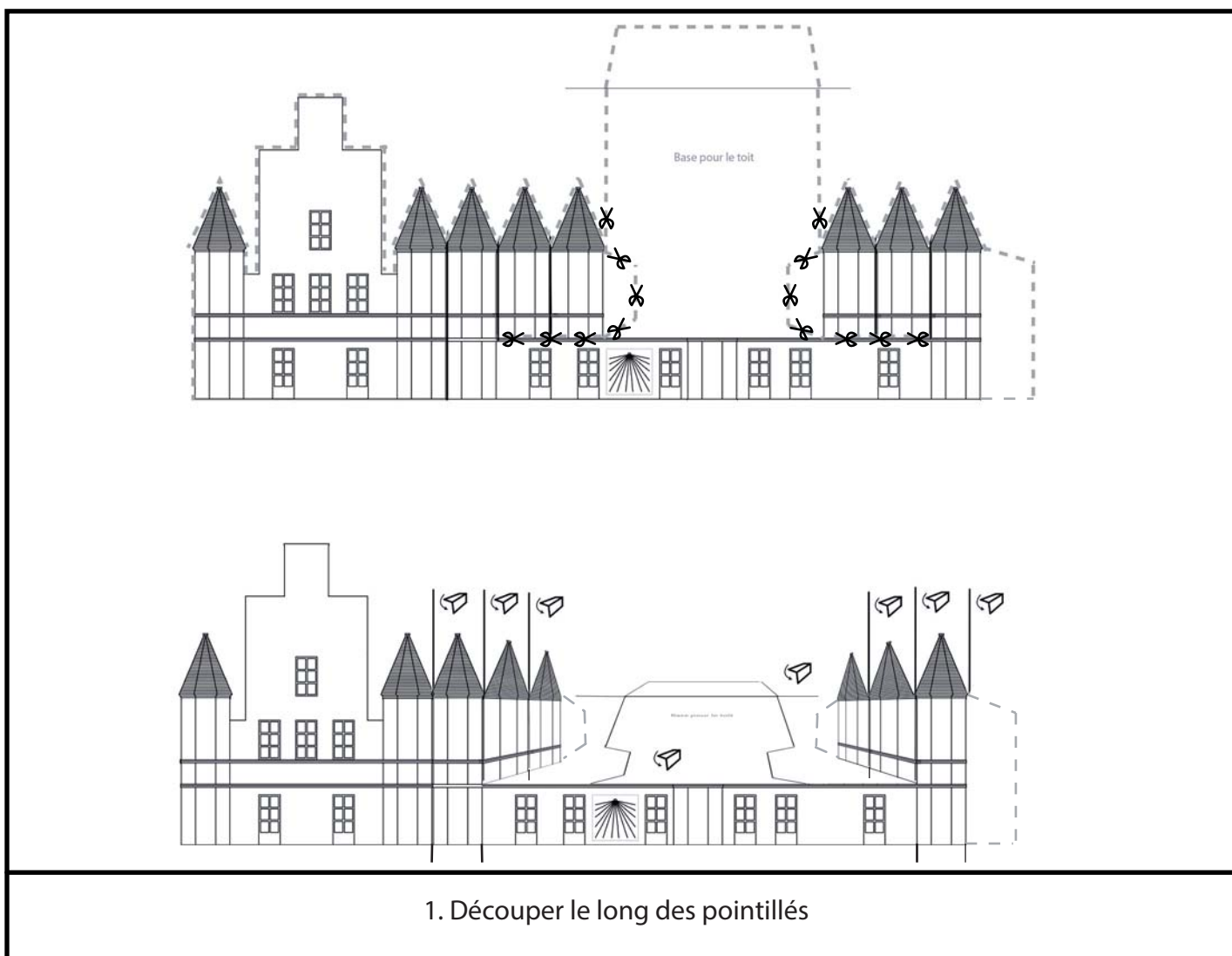

2. Fermer le bâtiment en collant les deux parties, replier la base du toit et coller le rabat

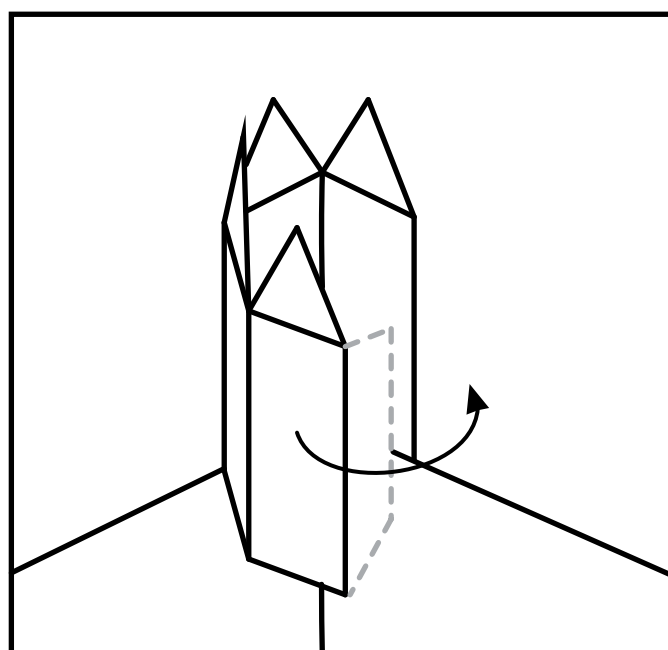

3. Replier les côtés des tourelles et coller le rabat

# 1. AULA MAGNA

## 1.1 bâtiment

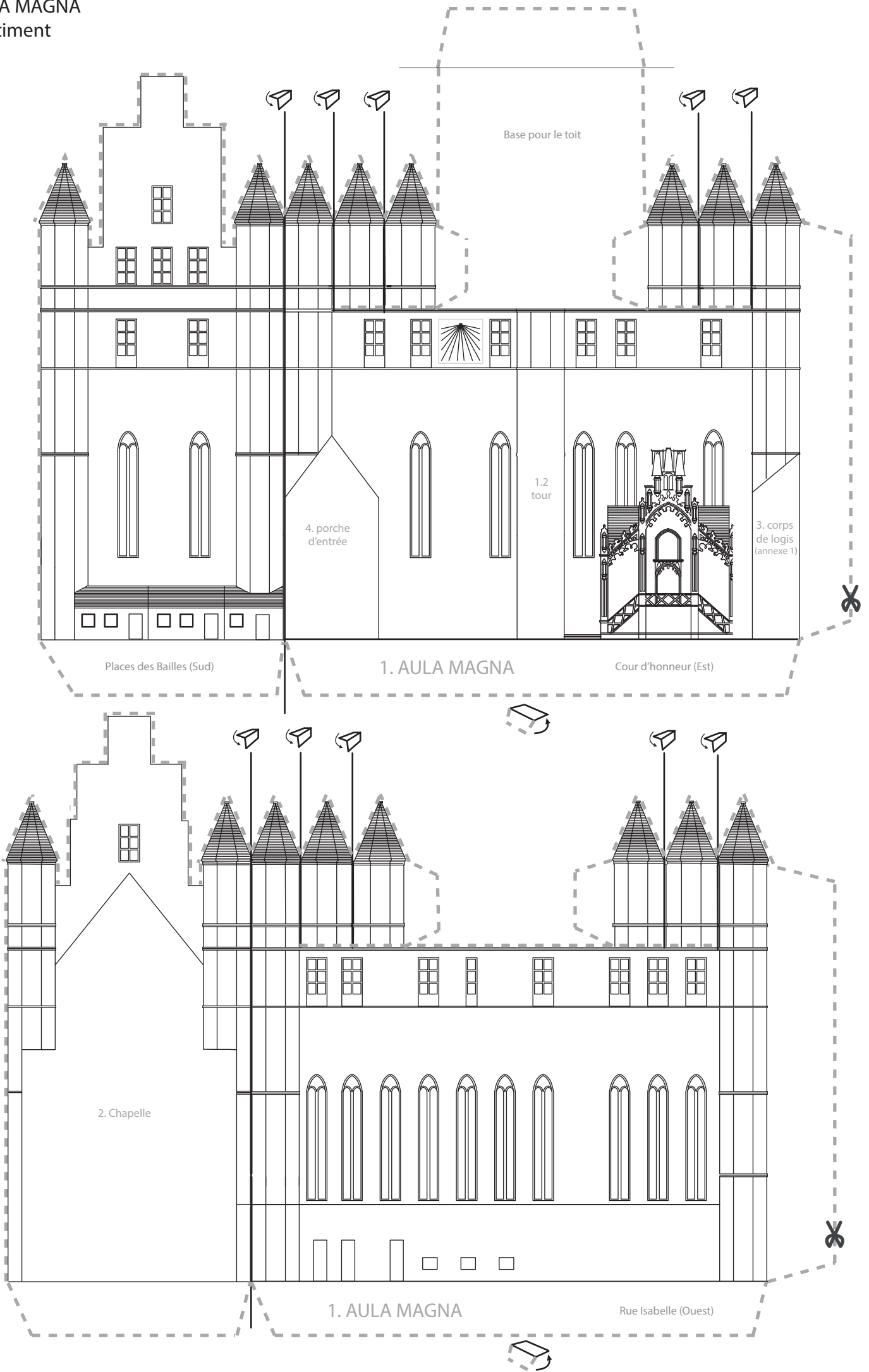

1. AULA MAGNA  
1.2 Tour

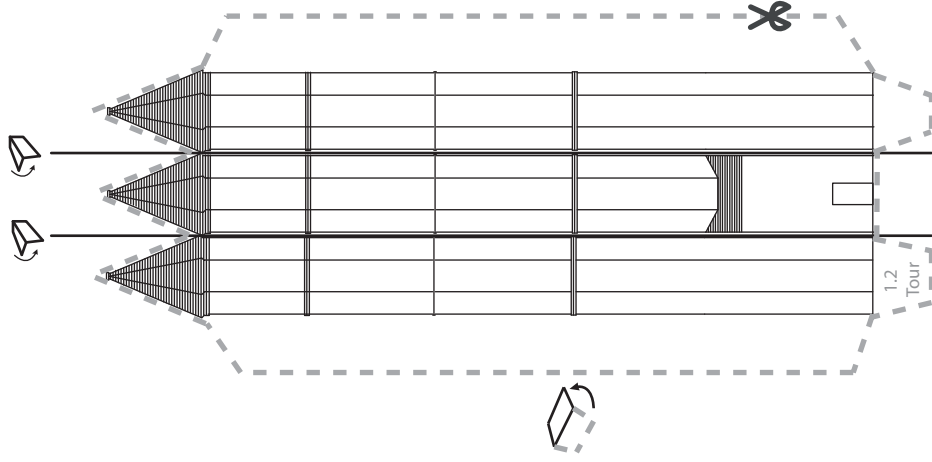

1. AULA MAGNA  
1.3 Toit

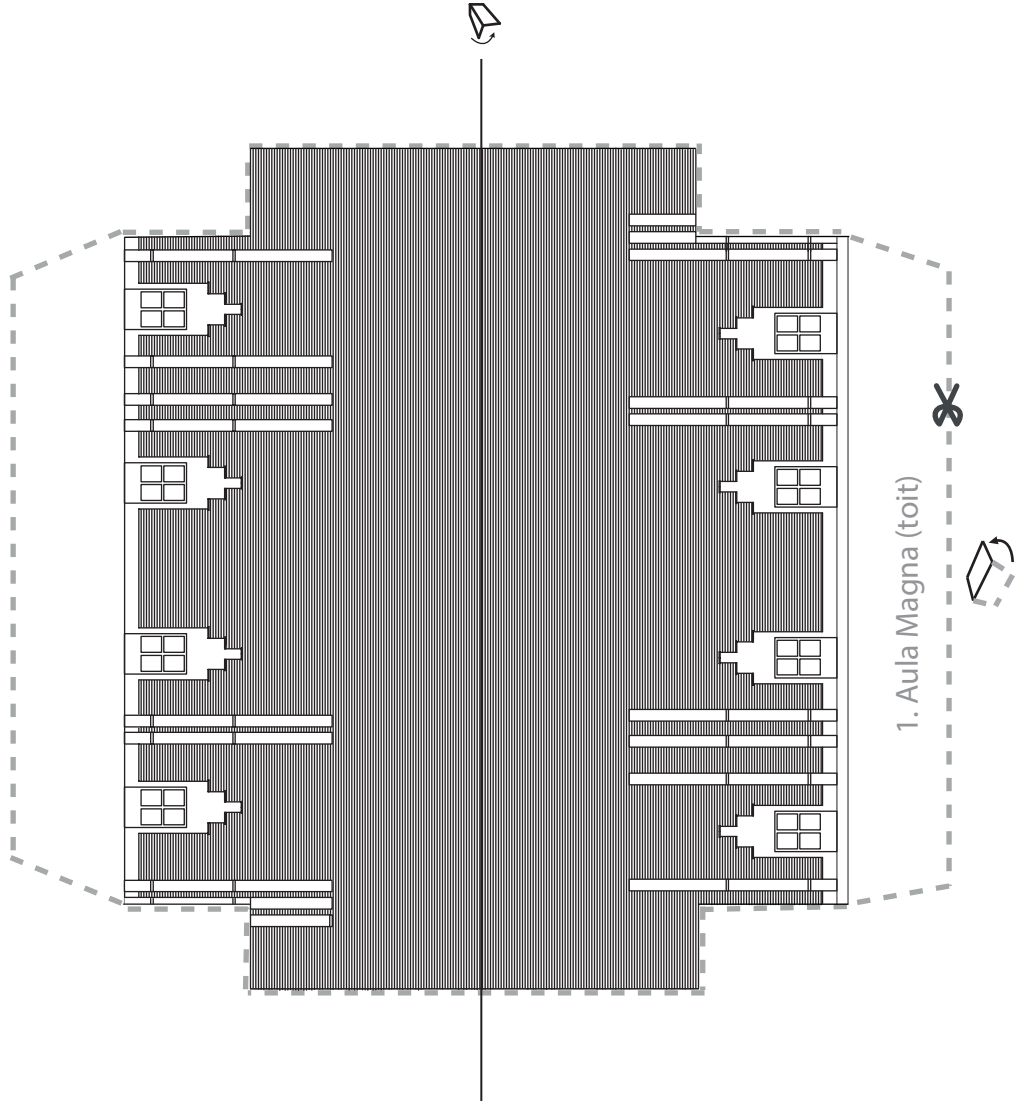

## Consigne de montage du toit de la chapelle

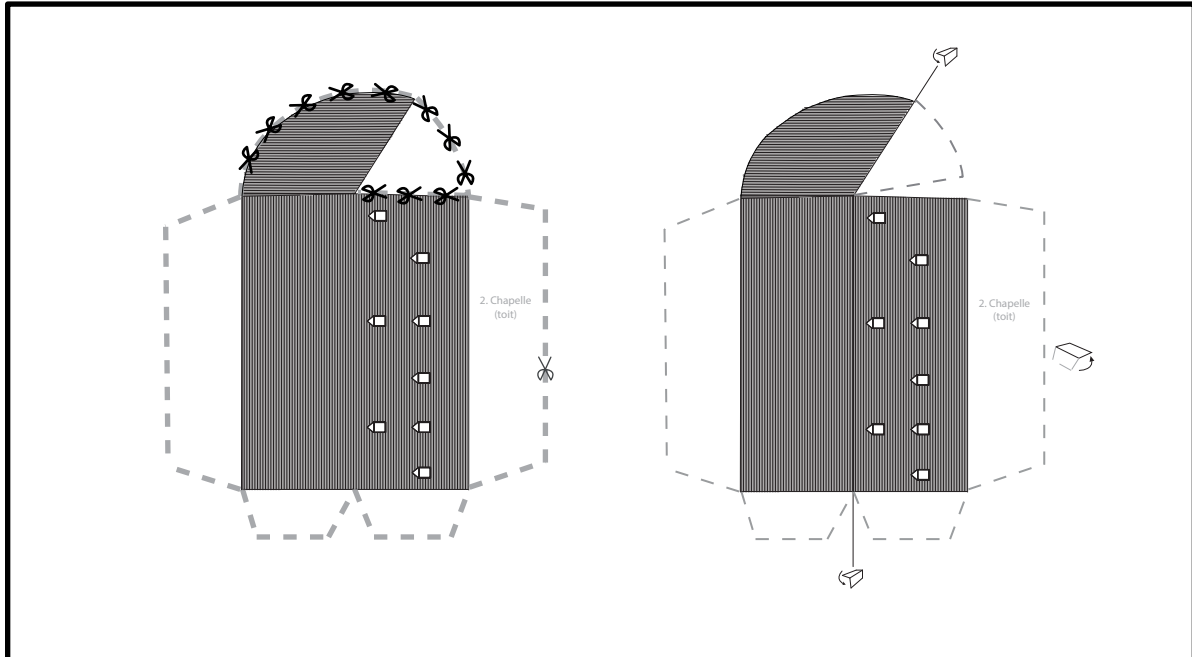

1. Découper le long des pointillés

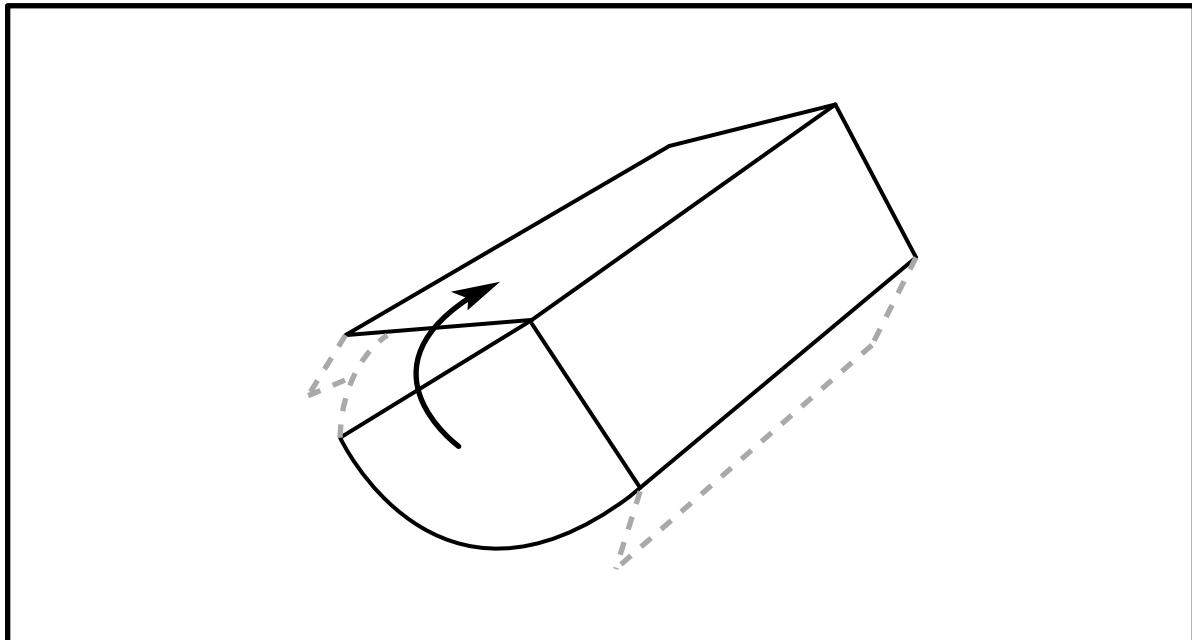

2. Plier le toit le long de la ligne, ainsi que l'arrondi.  
Coller le rabat de l'arrondi à la partie principale du toit pour le refermer.

## 2.2 Bâtiment (1er étage)

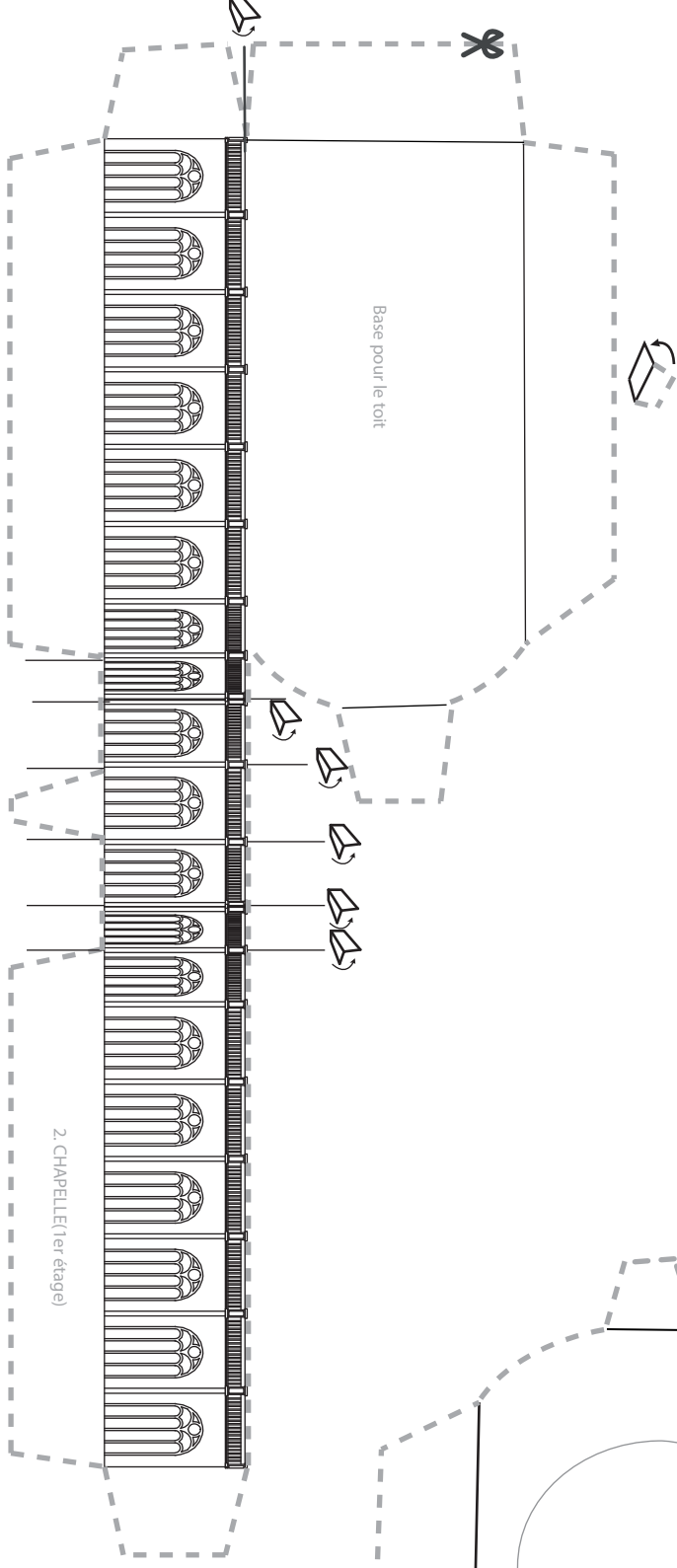

## 2. CHAPELLE 2.1 Bâtiment ( Rez- de-chaussée)

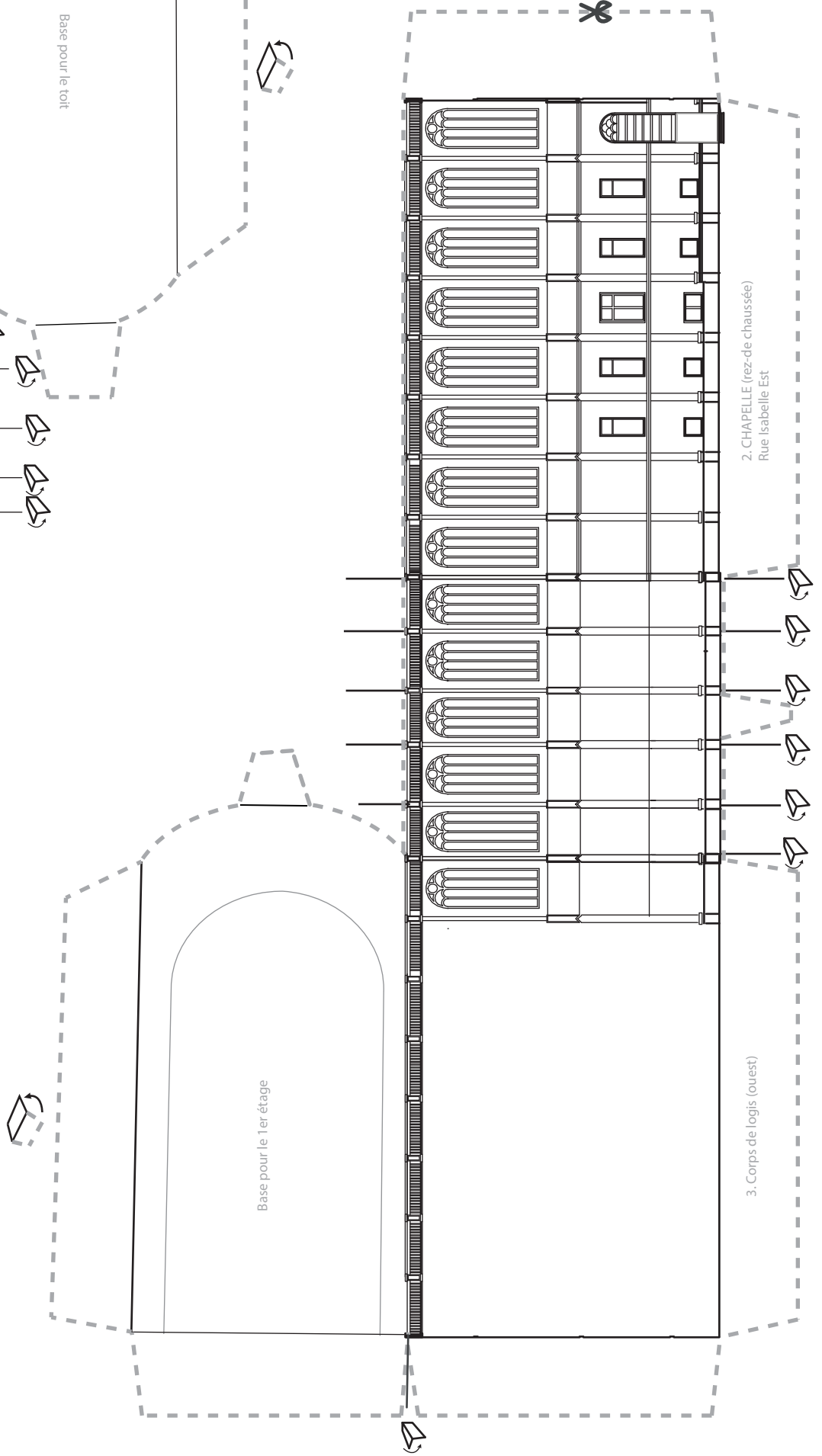



2. CHAPELLE  
2.3 Toit

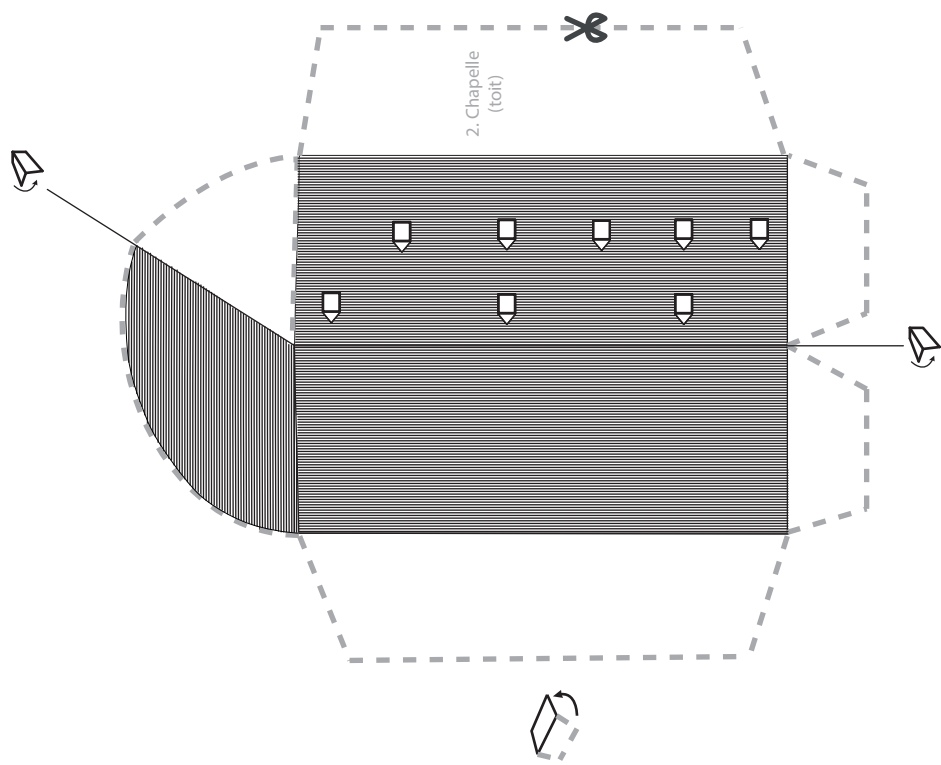

## Consigne de montage des toits de forme pyramidale

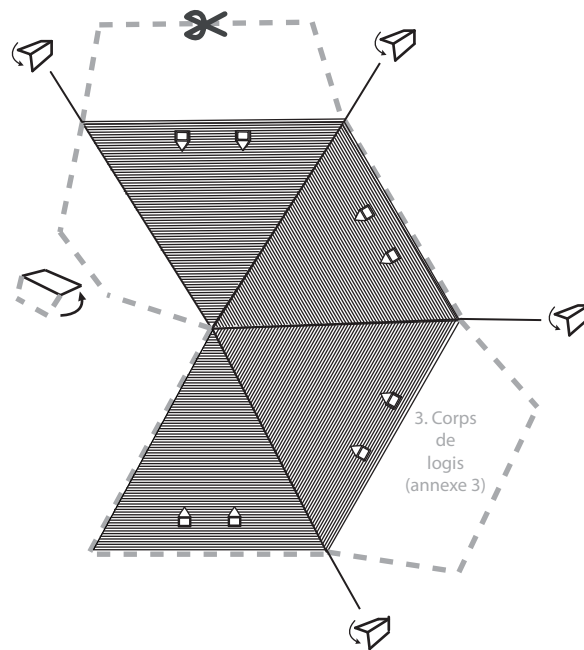

1. Découper le long des pointillés

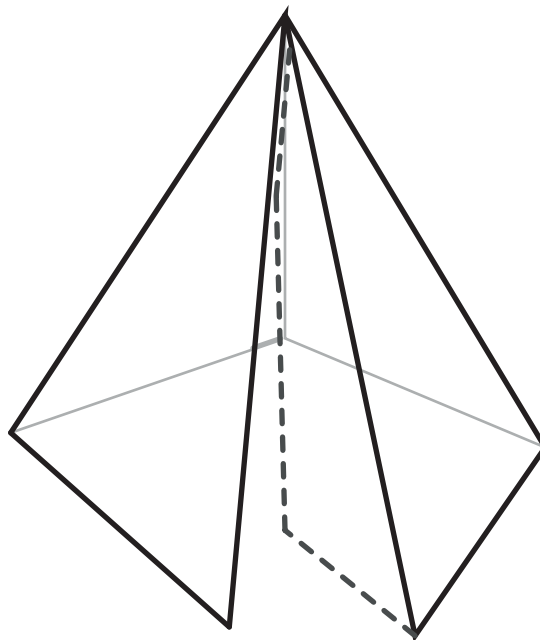

2. Plier les quatres faces de la pyramide. Coller le rabat

2. CHAPELLE  
2.4 Sacristie (bâtiment)

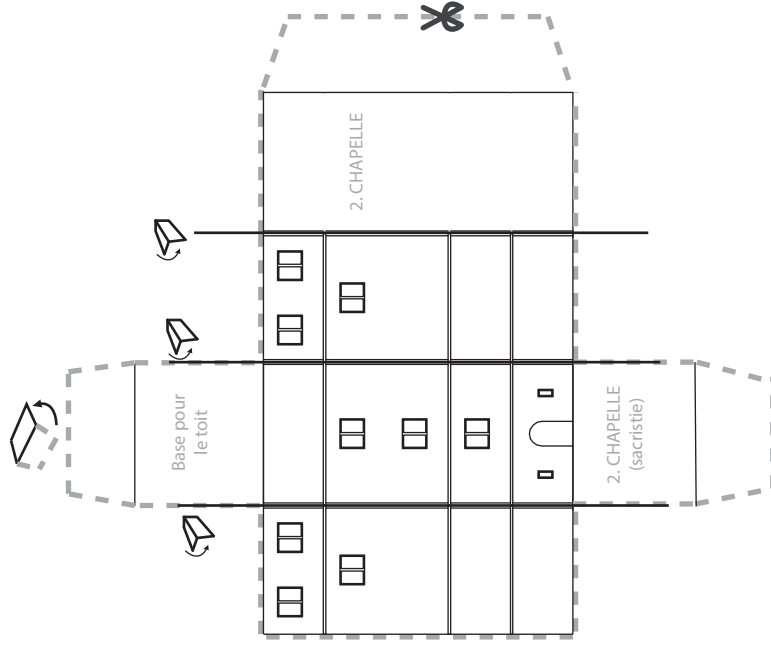

2.5 Sacristie (toit)

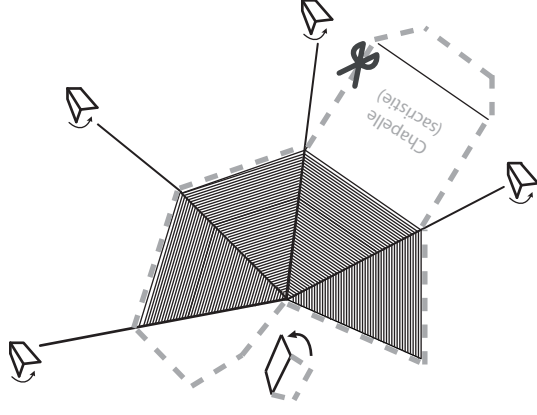

### 3. CORPS DE LOGIS

#### 3.1 Annexe 1 (bâtiment)

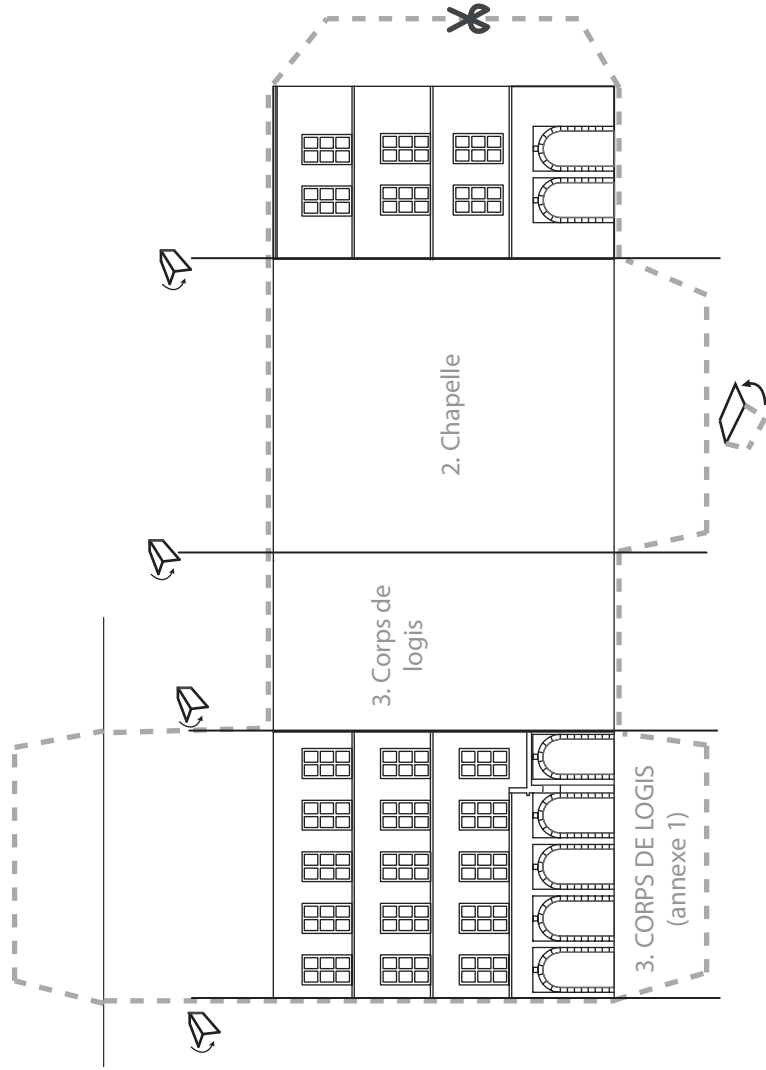

#### 3.2 Annexe 1 (toit)

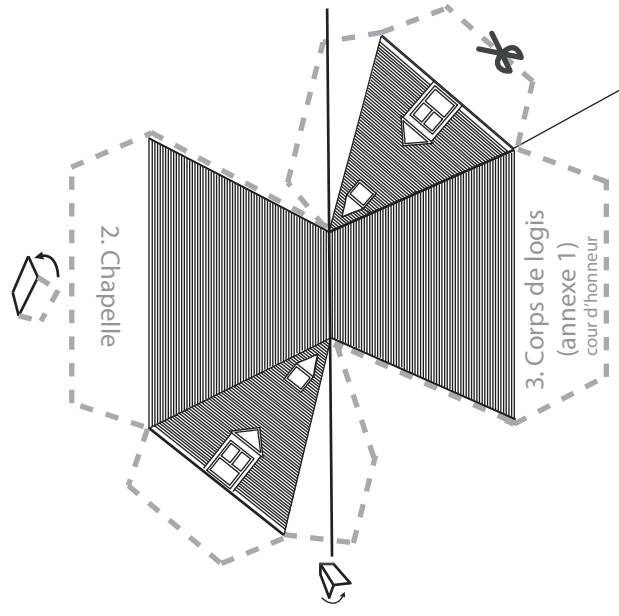

### 3. CORPS DE LOGIS 3.3 Pincipal (bâtiment)

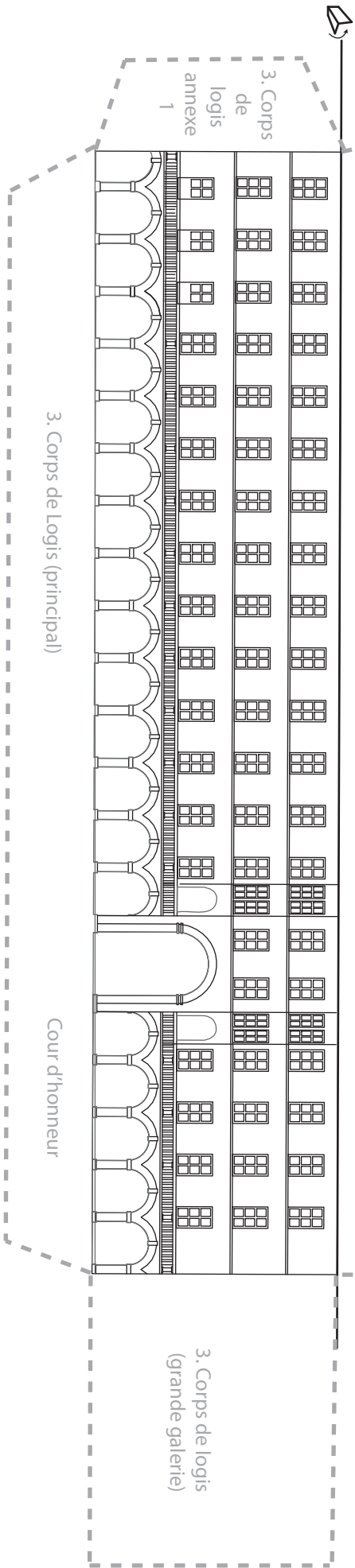

Base pour le toit

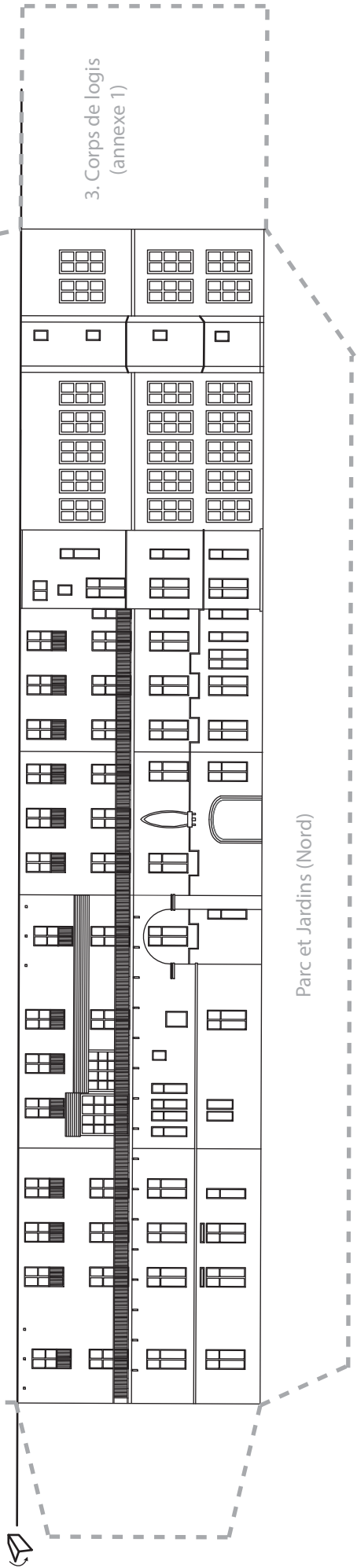

3. CORPS DE LOGIS  
3.4 Principal (toit)

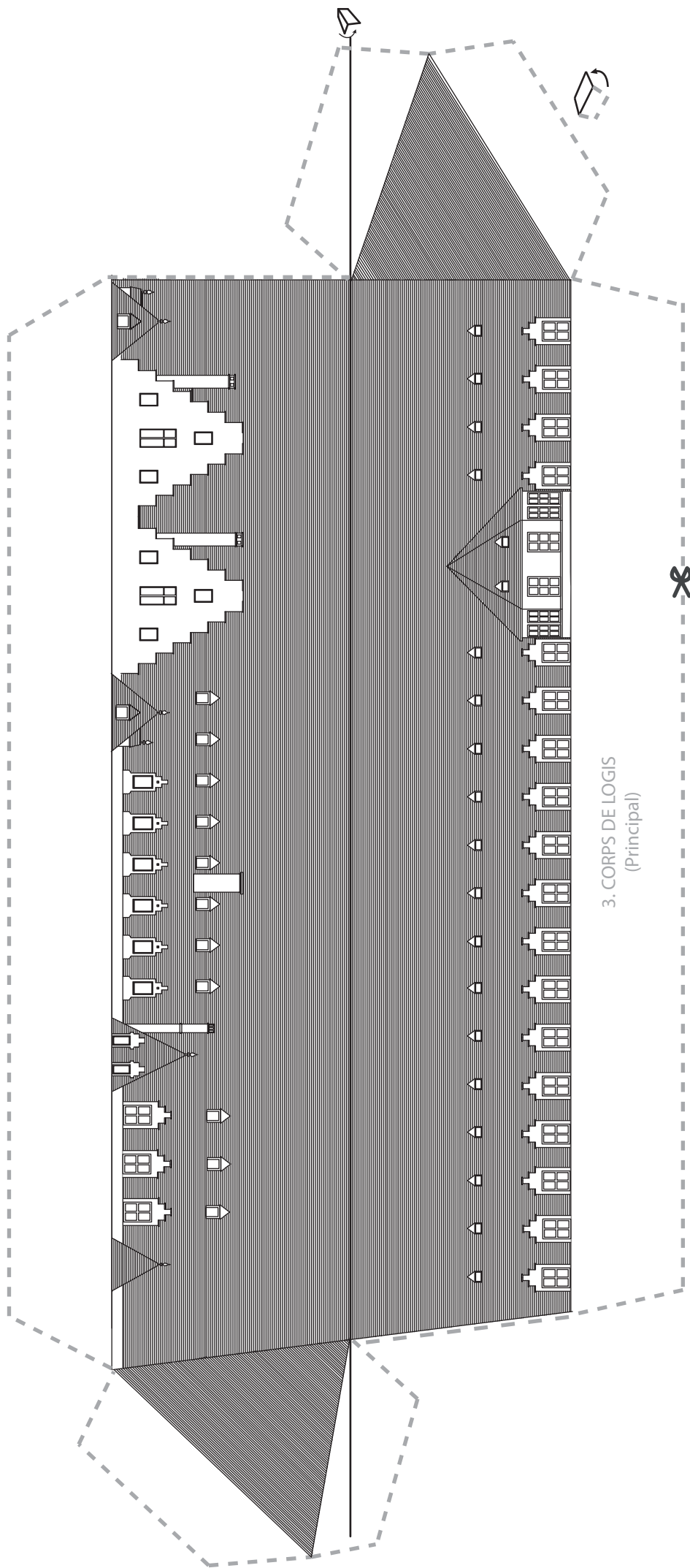

3. CORPS DE LOGIS  
(Principal)

3. CORPS DE LOGIS  
3.5 Grande Galerie

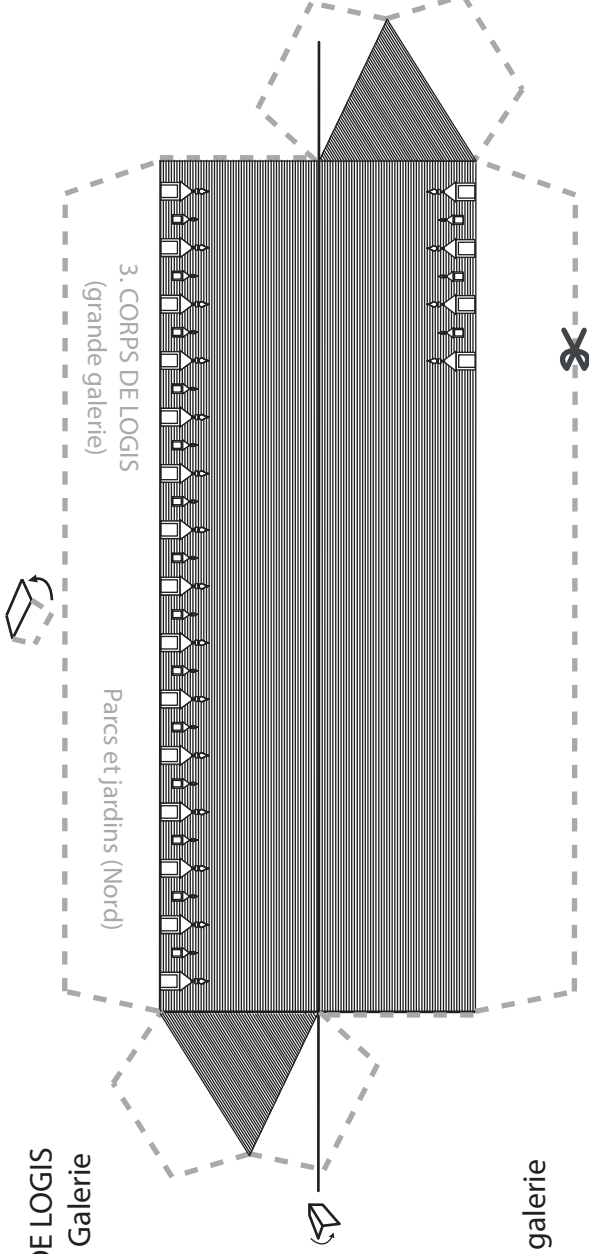

3.7 Annexe 2 (Toit)

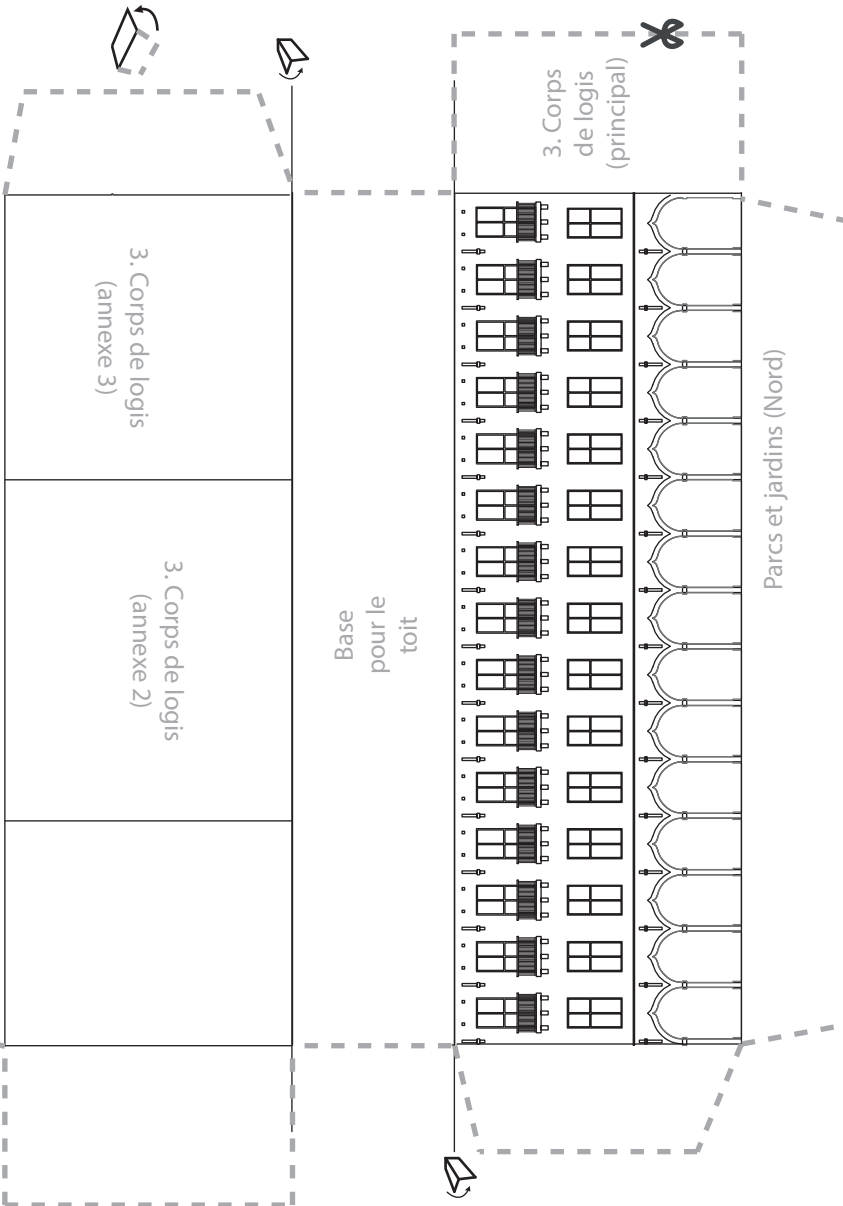
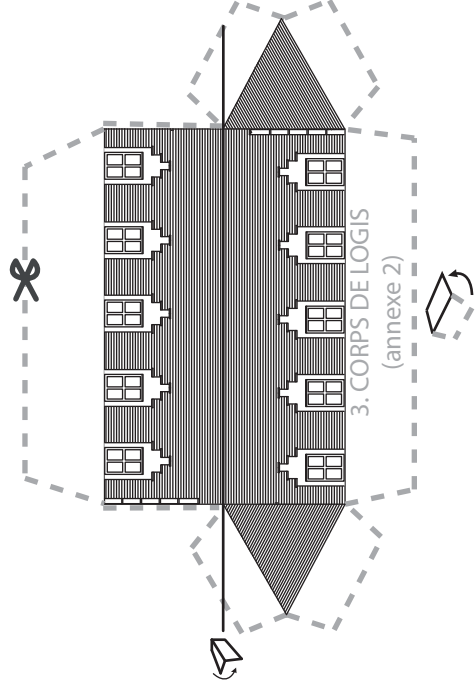

3.8 Annexe 2 (bâtiment)

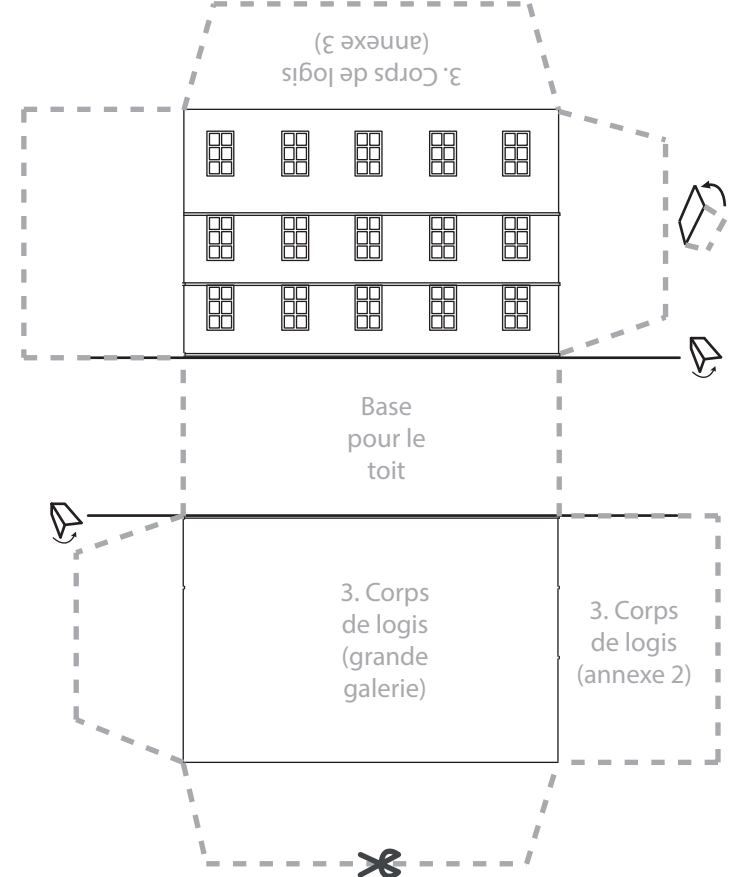

3. CORPS DE LOGIS  
3.9 Annexe (bâtiment)

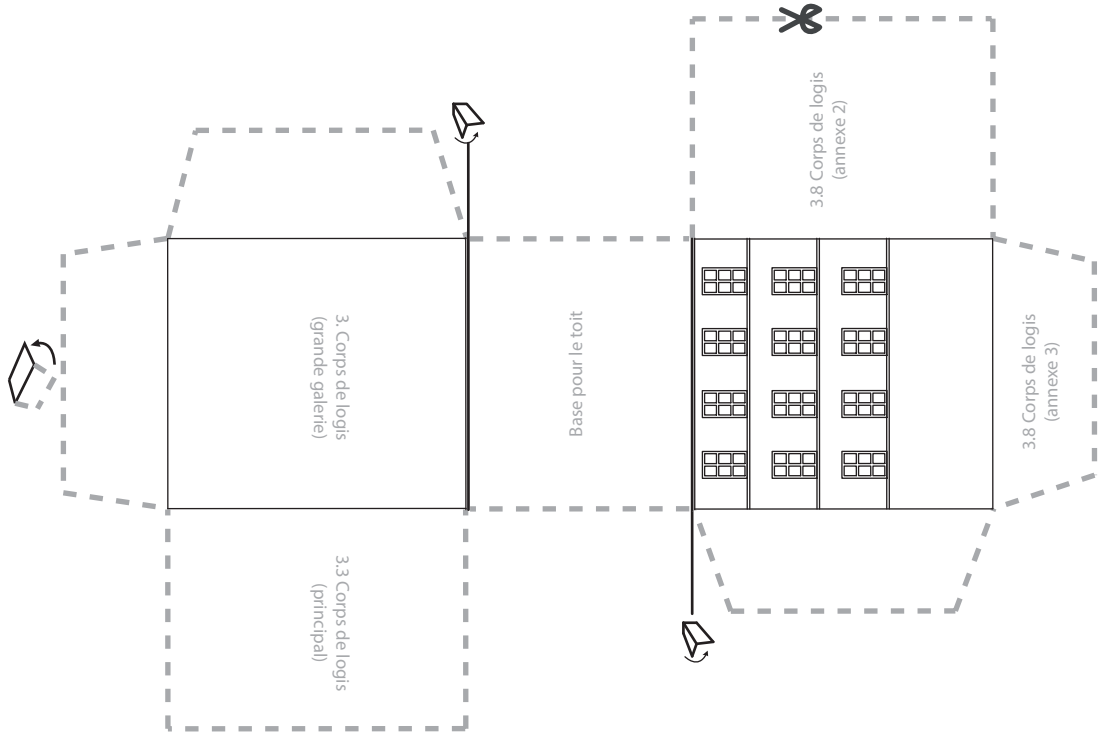

3. CORPS DE LOGIS  
3.10 Annexe 3 (toit)

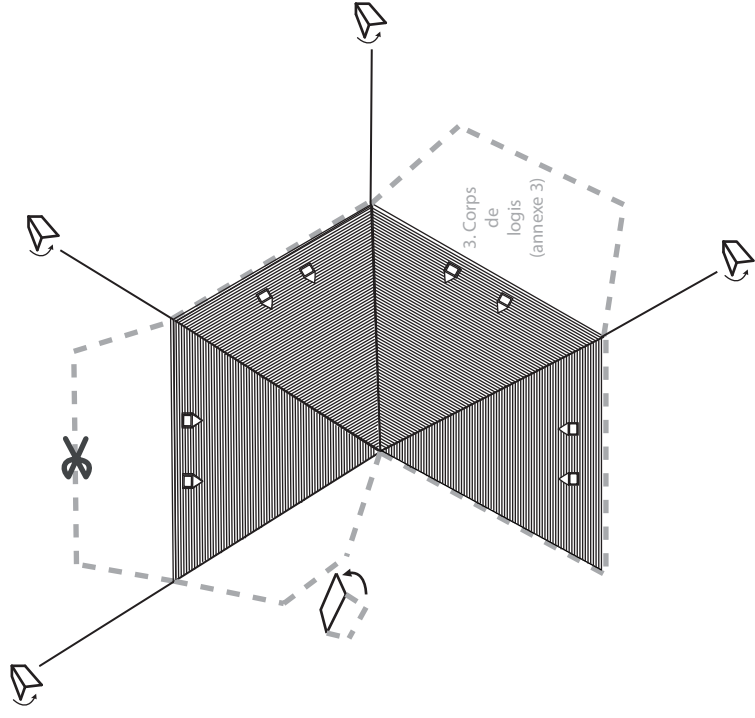



#### 4.2. Principal (tour)

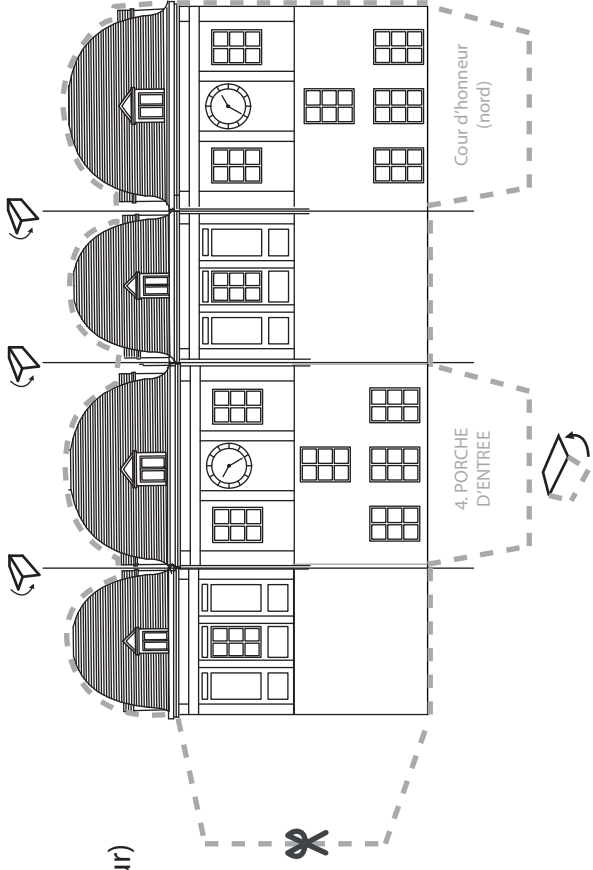

#### 4. PORCHE D'ENTREE 4.1 Principal (rez-de-chaussée)

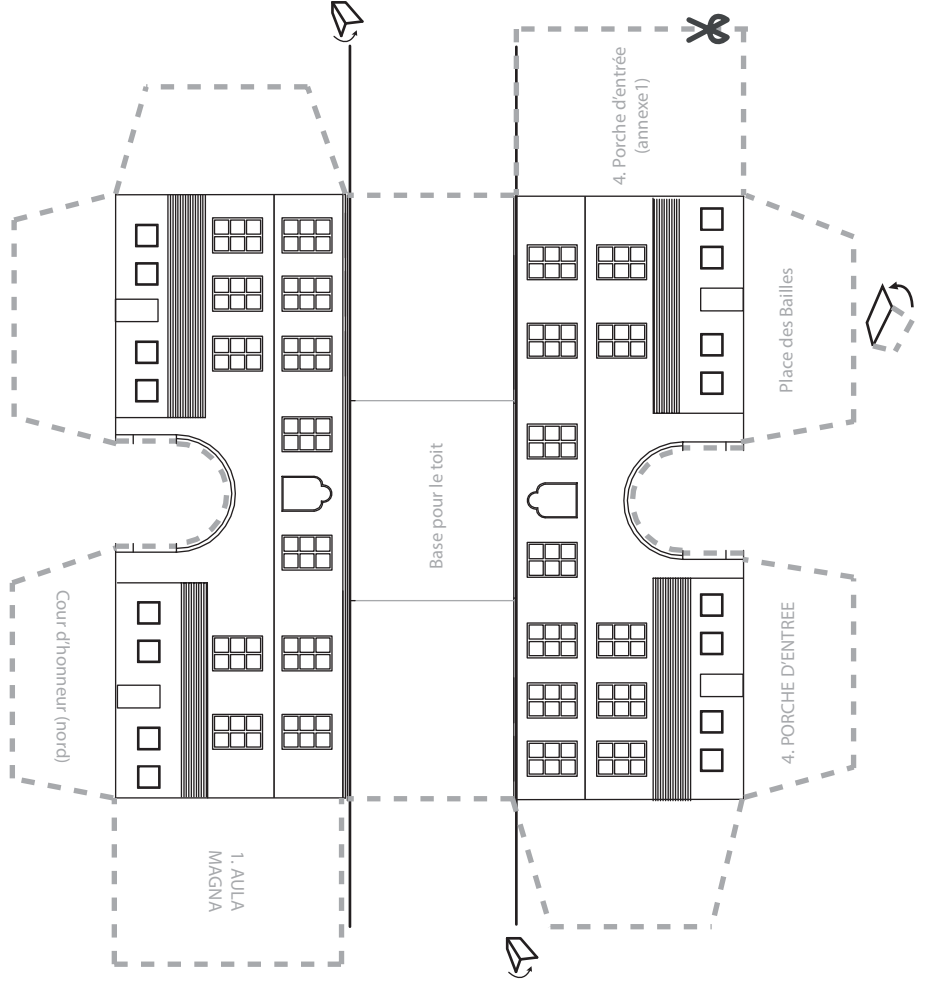

#### 4.3. Principal (toits latéraux)

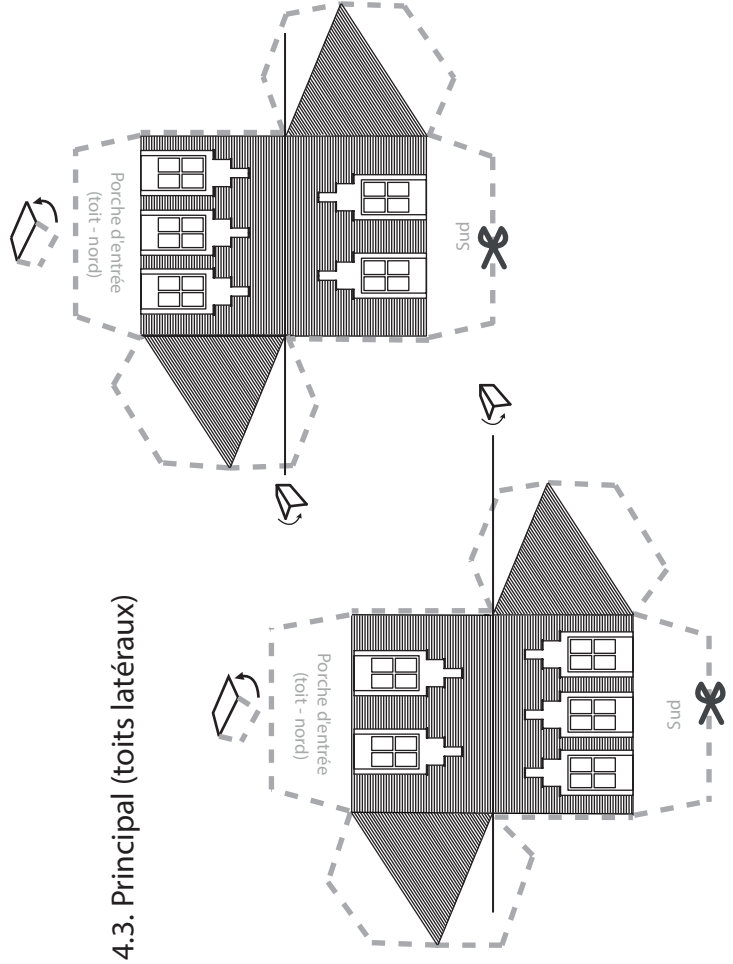

4. PORCHE D'ENTREE  
4.4 Annexe 1 (toit)

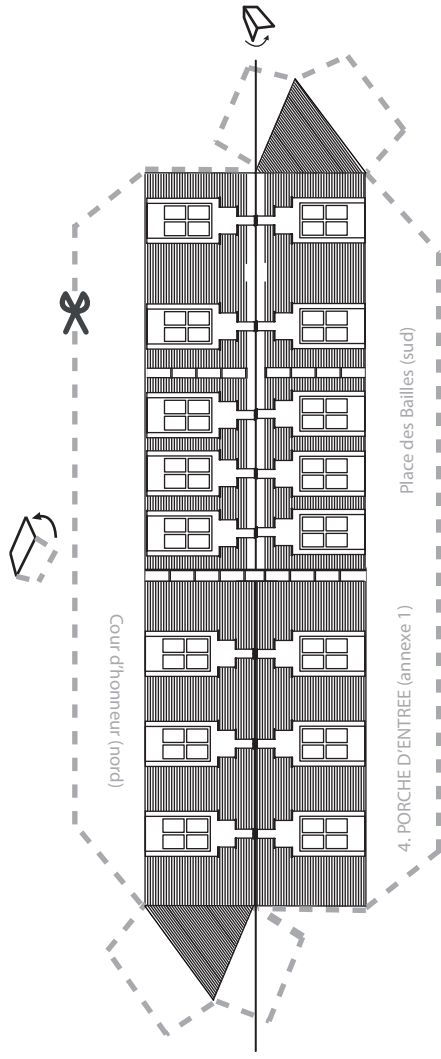

4.5 Bâtiment

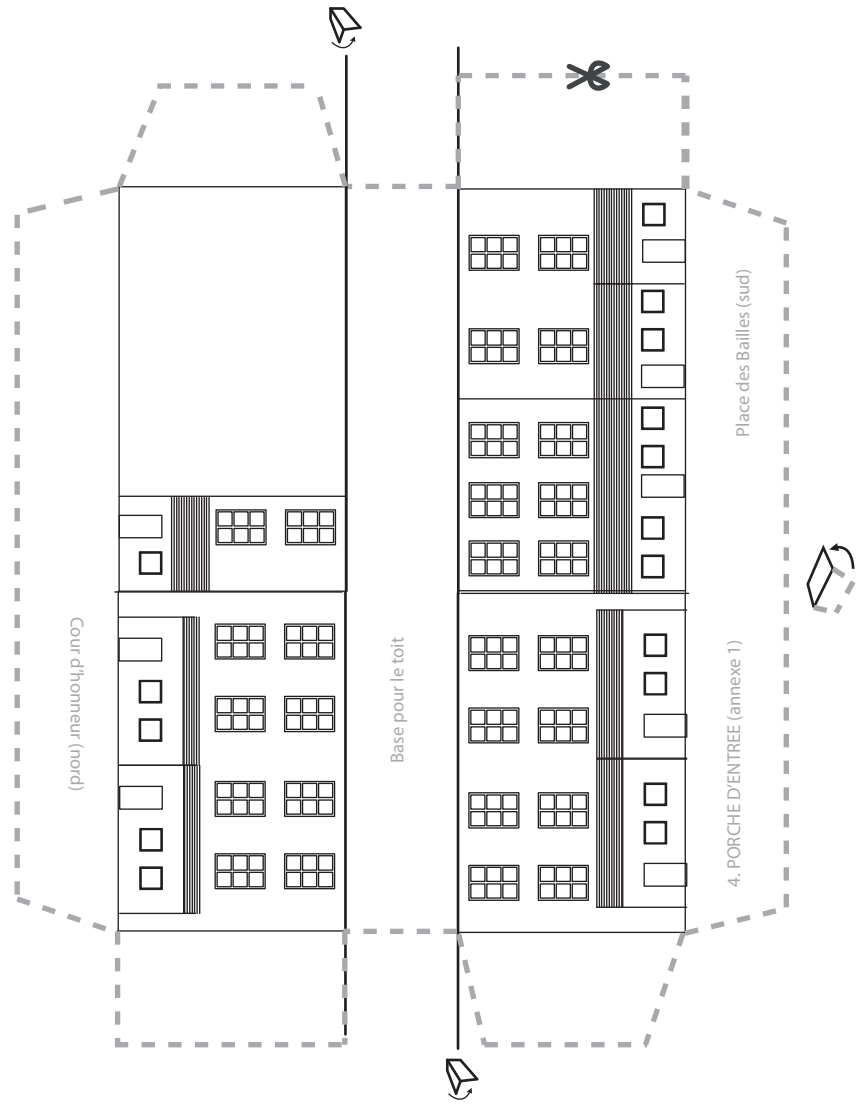

## 5. CUISINES

### 5.1 Bâtiment

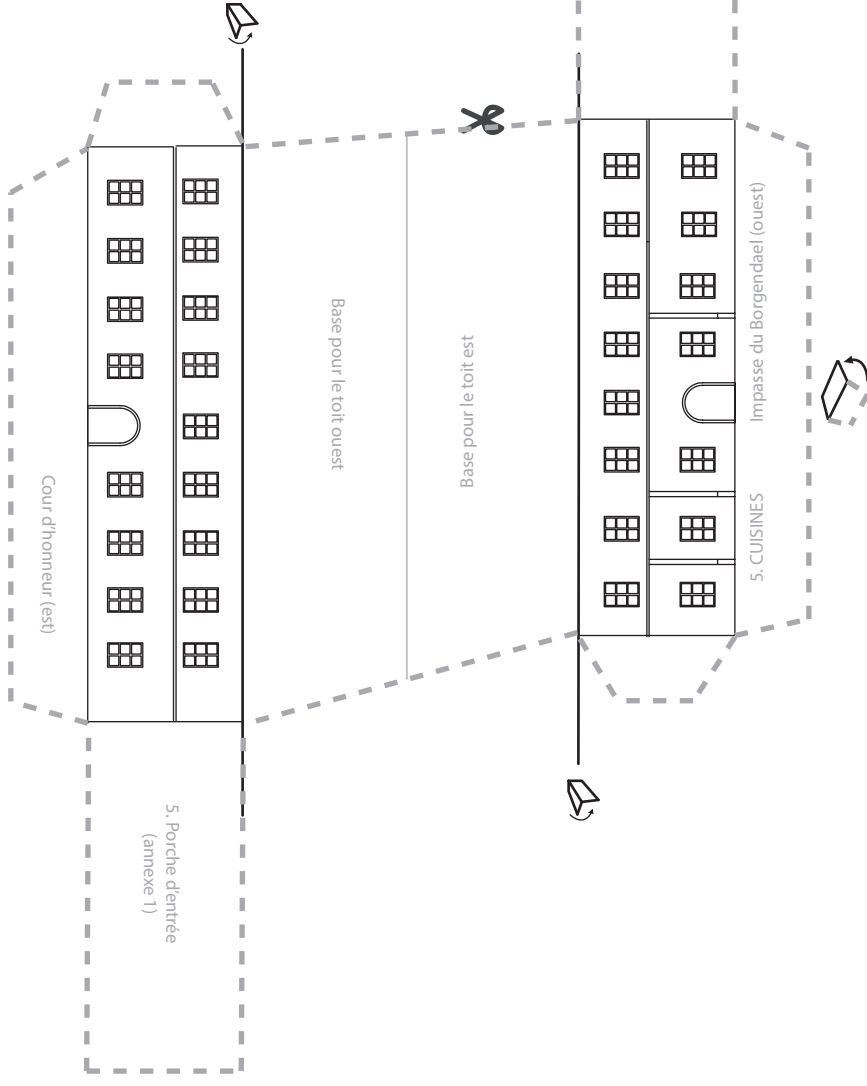

### 5.2 Toit (est)

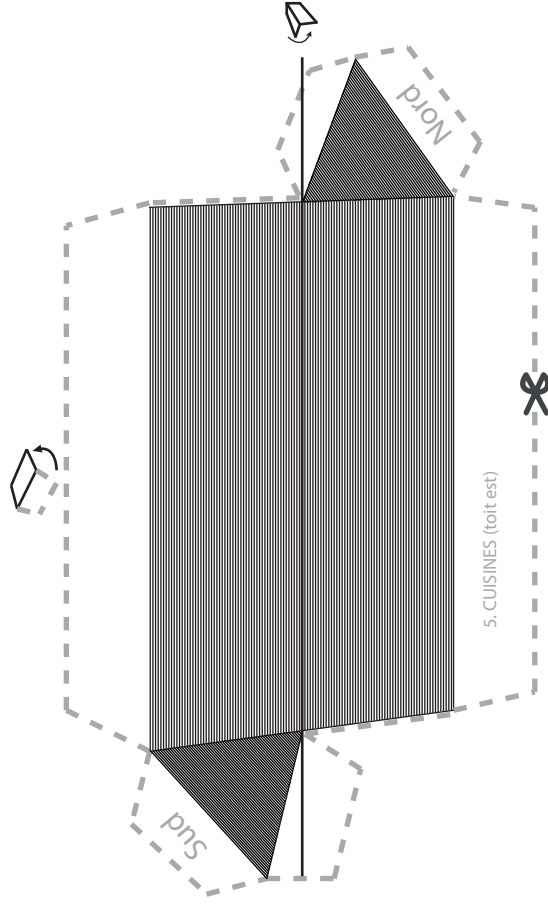

### 5.3 Toit (ouest)

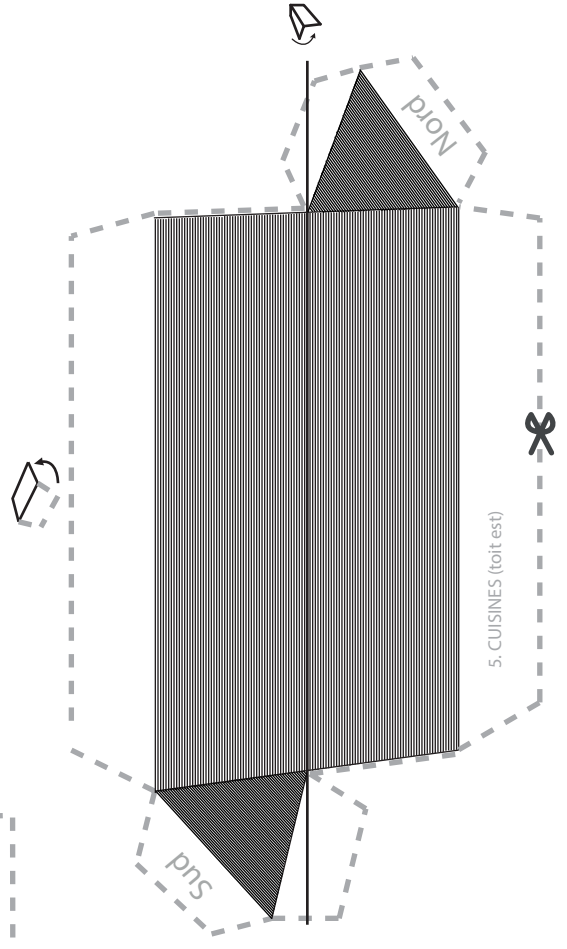

6. BORGENDAEL

